

## Miniature Pressure Regulators

Regulators are offered in either relieving or non-relieving versions. The relieving design maintains a constant pressure output even when downstream conditions change. As downstream pressure increases due to reduced flow, this increased pressure overcomes the regulator piston and the pressure is relieved to atmosphere to maintain a constant output pressure.

The non-relieving regulator does not automatically compensate for changes in downstream flow or pressure. There is no vent to atmosphere, as in a relieving type regulator, and the output pressure can increase due to a downstream flow.

## Plunger-Type Pressure Regulators

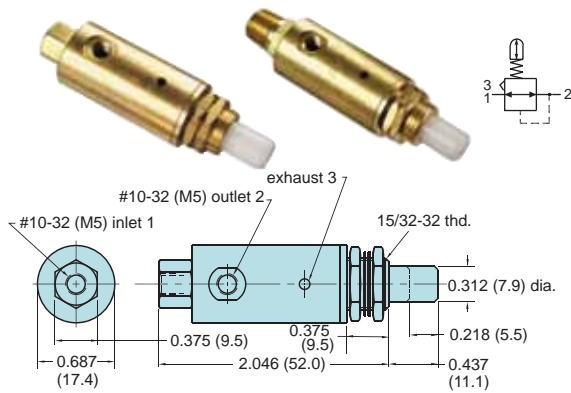

Plunger Travel: 7/32" Force For Full Stem Travel: 25 lb nominal

**Operation:** As plunger is depressed pressure increases proportionally to the travel; when plunger is released the input is closed and the output pressure is exhausted to atmosphere

Range (psig/bar)*	#10-32	1/8" NPT	M5
0-20/1.4	MAR-1C-2	MAR-1CP-2	MAR-1C-2-M5
0-30/2.1	MAR-1C-3	MAR-1CP-3	MAR-1C-3-M5
0-40/2.8	MAR-1C-4	MAR-1CP-4	MAR-1C-4-M5
0-50/3.4	MAR-1C-5	MAR-1CP-5	MAR-1C-5-M5
0-60/4.1	MAR-1C-6	MAR-1CP-6	MAR-1C-6-M5
0-70/4.8	MAR-1C-7	MAR-1CP-7	MAR-1C-7-M5
0-100/6.9	MAR-1C	MAR-1CP	MAR-1C-M5

\* Outlet pressure is based on 7/32" stem travel. If stem is depressed further, the outlet pressure will increase.

## Replacement Air Filter with Element



**Medium:** Air Only **Filtration:** 35 micron

**Input Pressure:** 0-250 psig max. **Material:** Brass

**Air Flow:** 5.0 SCFM @ 50 psig; 9.0 SCFM @ 100 psig

**Mounting:** Direct or inline

**Cleanout:** Press clean-out valve stem periodically to remove accumulated water. For complete cleaning, filter body unscrews at point "A" without disturbing piping. DO NOT DISASSEMBLE UNDER PRESSURE. Remove screw and filter element to clean or replace

- Panel mounting permits unit to be located with other controls on a control console or panel board for pilot operation of larger regulators or for remote control; mounting nuts and lockwashers furnished
- Small, compact - ideal for mounting on individual jigs and fixtures as well as in control circuits

**Medium:** Air

**Materials:** Brass body, Buna-N seals, stainless steel stem and spring

**Air Flow:** 3 SCFM @ 50 psig; 5 SCFM @ 100 psig; 120 l/min. @ 6 bar

**Input Pressure:** 300 psig/21 bar max.

**Mounting:** 15/32-32 thread. Nuts and lockwashers furnished

**Adjustment:** By means of a knob with micro-adjustment (40 pitch thd.)

## Adjustable Pressure Regulators

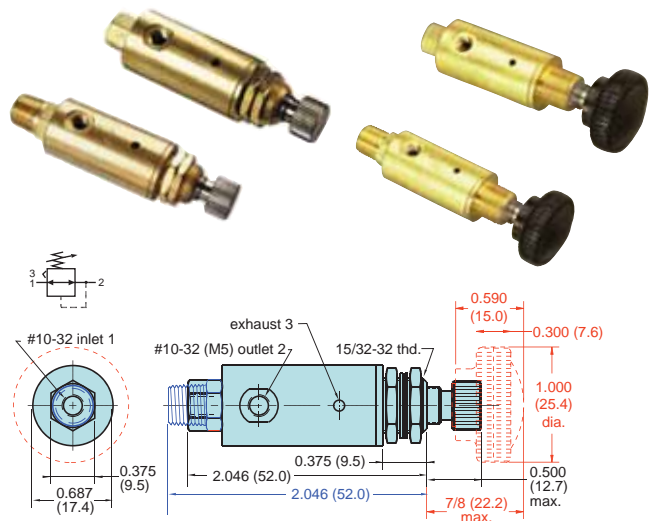

Range (psig/bar)	#10-32	Knob	1/8" NPT	Non-Relieving	M5
0-20/1.4	MAR-1-2	MAR-1K-2	MAR-1P-2	MAR-1NR-2	MAR-1-2-M5
0-30/2.1	MAR-1-3	MAR-1K-3	MAR-1P-3	MAR-1NR-3	MAR-1-3-M5
0-40/2.8	MAR-1-4	MAR-1K-4	MAR-1P-4	MAR-1NR-4	MAR-1-4-M5
0-50/3.4	MAR-1-5	MAR-1K-5	MAR-1P-5	MAR-1NR-5	MAR-1-5-M5
0-60/4.1	MAR-1-6	MAR-1K-6	MAR-1P-6	MAR-1NR-6	MAR-1-6-M5
0-70/4.8	MAR-1-7	MAR-1K-7	MAR-1P-7	MAR-1NR-7	MAR-1-7-M5
0-100/6.9	MAR-1	MAR-1K	MAR-1P	MAR-1NR	MAR-1-M5

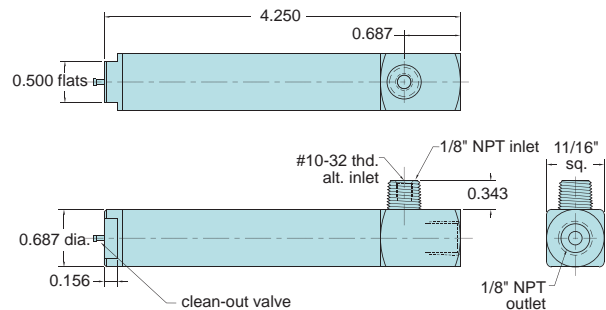

Part No.	Description
MAF-1	Replaceable Air Filter with Element
12382	Low Pressure Drop, Concentric, Chemically-Inert 35-micron Filter Elements